

Fax Queuing

Maximize sales by offering customers the ability to fax signed orders directly to your contact center. Fax Queuing distributes faxes to contact center agents directly, making your site more responsive and providing a superior level of customer service. By applying the intelligent routing and reporting capabilities of NEC's Unified Communications for Business to faxes, Fax Queuing ensures that every customer contact is handled in a timely and professional manner.



Introduction

Many industries still rely on the paper trail of signatures. For many companies, faxes are still the preferred order-taking medium. Fax Queuing improves the access, control and security of fax communication by allowing customers to send signed orders and other important documents directly to your contact center.

Table of contents

Introduction	1
Business Drivers	1
Overview	1
How does Fax Queuing work?	1
Licensing	2
Core Features and Benefits	2
Features	2
Benefits	2
The Fax Queuing Process	3
Physical Architecture Overview	4
Notifying Agents of Incoming Faxes	5
Features	5
Benefits	5
Example	5
Fax Delivery to Agent	6
Benefits	6
Example	6
Additional Fax Queuing Functions	7
Features	7
Benefits	8
Fax Queuing Reply	8
Features	8
Benefits	8
Reports	12
Features	12
Benefits	12
Media Viewer	14
Features	14
Benefits	14
Example	14

Introduction

As a fully integrated module of NEC's Unified Communications for Business (UCB), Fax Queuing applies all the skills-based routing and queuing parameters of UCB to your customers' faxes. This means you can direct faxes to specific individuals or departments that are best equipped to respond to them.

Fax Queuing is also fully integrated into UCB's comprehensive reporting package, ensuring that contact center managers have a complete picture of all customer contact, regardless of the medium used.

Fax Queuing requires the agent to be running Agent Desktop in order to log in and take delivery of faxes.

Are you tired of waiting at the fax machine for faxes to arrive – or worse still, missing them because they've got caught up in a pile of other work for somebody else? Fax Queuing delivers directly to the appropriate agent so they can view and/or print the fax at their own discretion, at the best time for them and the contact center.

Business Drivers

- Signatures on faxes are still the only electronic legal tender used by some organizations. Maximize the sale opportunities for your business by giving potential customers a simple way send signed orders through to immediately begin the purchase process.
- Give your customers instant contact with agents in your contact center, minimizing misplaced orders and delay frustrations.
- Reduce paper confusion and interruptions by providing your contact center agents with the ability to view faxes on screen.
- By instantly responding to the inbound fax request, your agents can maintain a fluid process that is easily tracked as required.
- Centralize the management of all forms of customer interaction within a single environment.
- Improve productivity of your contact center by applying skills-based routing to all communications.

- Centralized reporting on all contact methods gives managers the tools they need to maximize contact center productivity.

Overview

How does Fax Queuing work?

Fax Queuing prioritizes faxes for your contact center in the same way as phone calls. Faxes are stored in the database server, which is monitored by CT Control. CT Control recognizes when your agent is available, i.e., ready to receive a fax. A fax is then moved from the database server to agent Desktop.

Agents are delivered faxes only as they are ready to deal with them. Agents who are logged out, on a break, or already dealing with calls¹, are not delivered faxes. Once the fax is delivered, if the agent takes too long to open the fax², CT Control pulls it back and then puts it back into the queue mailbox. This is analogous to phone calls being pulled back and returned to the front of the queue when phone agents do not answer.

Once an agent opens the fax, the fax will not be pulled back. These 'queued faxes' appear in Agent Desktop in the fax plug-in view, an item in the Desktop menu bar that is only available with Fax Queuing. Agents can be configured to handle as many concurrent queued faxes as required.

All queued faxes are displayed in Agent Desktop as 'calls' in a queue. Fax 'calls' are displayed in exactly the same format as queued phone calls.

You can require wrap-up information to be entered (via Agent Desktop) upon ending the fax 'call'; this information can be reported on.

Integration between Agent Desktop and Fax Queuing is seamless: changes to the fax status are reflected in Agent Desktop, as when the fax is opened, the Agent Desktop queuing screens display the agent as having 'answered' the fax, or being 'connected' on a fax 'call'. Agent Desktop continues to display the agent as being on the fax call until the fax is deleted (this is analogous to

¹ A maximum number of calls can be set, per medium, for each class of agent.

² The Administrator can pre-specify how long a fax waits before being pulled back and redelivered.

having hung up), providing further insurance against faxes being lost and never dealt with.

Licensing

Fax Queuing requires the following licenses...

1. Each agent must be licensed to run Fax Queuing
2. Agent Desktop is required in order to log into the queues, and to view and process faxes.

Fax Queuing comes with Fax Messaging, providing agents with the ability to send and receive personal faxes from/to the desktop using their voice mailbox for inbound faxes and Microsoft® Fax Console for outbound.

Core Features and Benefits

Features

Fax Queuing provides the following functionality:

- All the functionality of UCB such as skills-based routing, reports, operating modes, etc. are available in Fax Queuing.
- Agents can reply to faxes they receive from fax queues via Desktop.
- Queue and agent data can be reported on via the Queue Fax Report.
- Queue and agent data can be reported on via the Queue Fax Report.
- A central repository of custom fax reply templates can be created using the Template Editor Tool.
- Single administration interface for setting up agents for dedicated or blended delivery
- Supervisors can view both details about and content of previously handled faxes via a Fax Media Viewer.
- As well as the Media Viewer, an immediate "safety net" or administrative backup option is available, allowing each agent, or each queue, to automatically print all faxes either on arrival in the queue, or on delivery to the agent. UCB security options determine how this functionality should be controlled, i.e., by the agent, supervisor or Administrator.

Benefits

Fax Queuing offers some unique benefits:

- Fax Queuing gives the customer the option of committing to a sale with a confirmed, signed order – this is not available in any medium other than hand delivery or face-to-face.
- Fax Queuing is easy to use for both customer and agents, saving the time and expense associated with training.
- Customer service levels and sales revenues can be dramatically improved by offering the ability to send an order directly.
- Skills-based routing ensures that faxes are directed to the agent best able to handle them, in the same way that calls are. This improves customer service and reduces handling time.
- The module includes powerful reporting tools, bringing the monitoring of fax contacts into the realm of contact centers.
- UCB provides a single, fully integrated solution for telephone, fax and web based contacts.
- Replying to faxes via Desktop is more time efficient than the usual three-step method of print, pick up and send fax, which often involves visiting a fax machine in another part of the office.
- Fax traffic can be reported on for contact center performance analysis. This allows supervisors and managers to apply standard contact center analysis to this media type.
- The use of standard fax reply templates guides agents in their replies, ensuring targeted responses that comply with the contact center's communications standards.
- With the option available to print backup confirmation, many managers feel more confident to progress to highly desirable paperless office. Alternatively, this may be a standard administrative requirement.

The Fax Queuing Process

The following is a typical example of the Fax Queuing process:

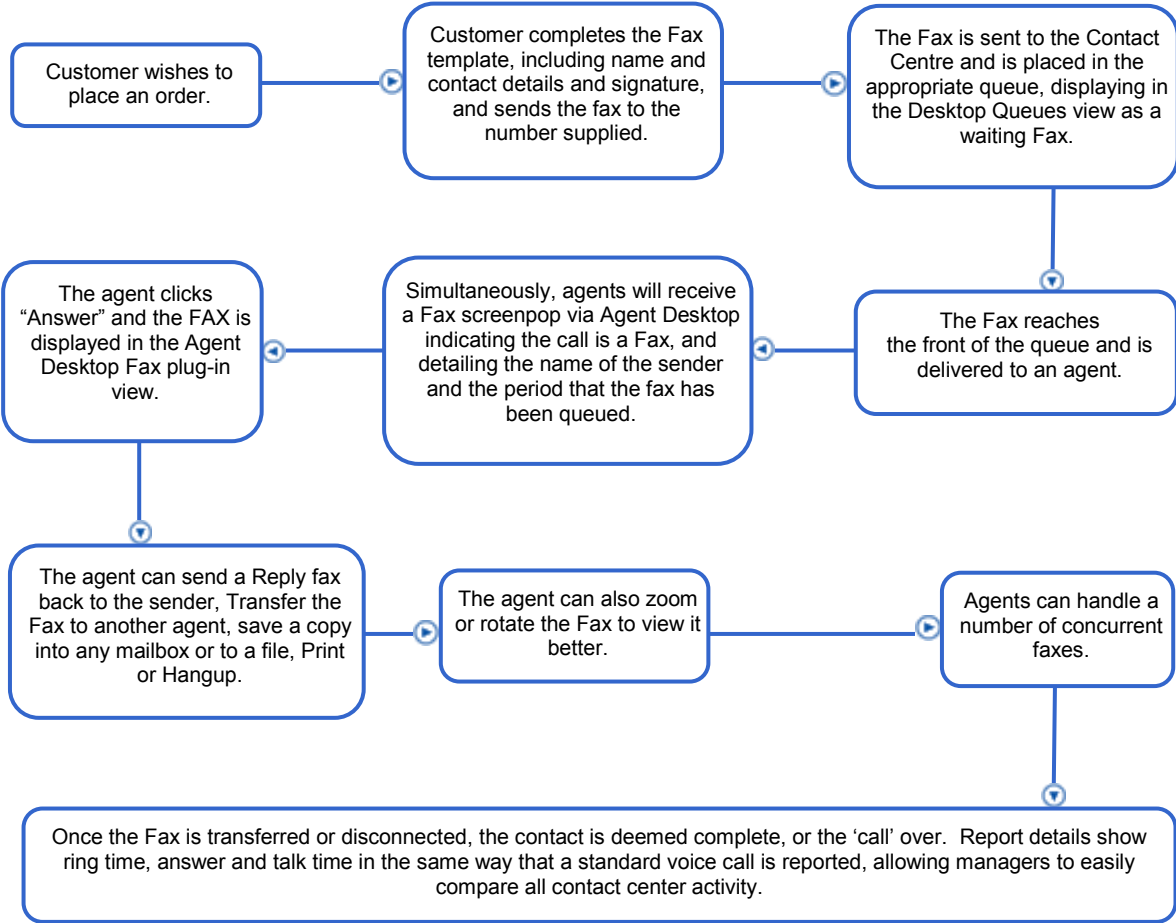

Physical Architecture Overview³

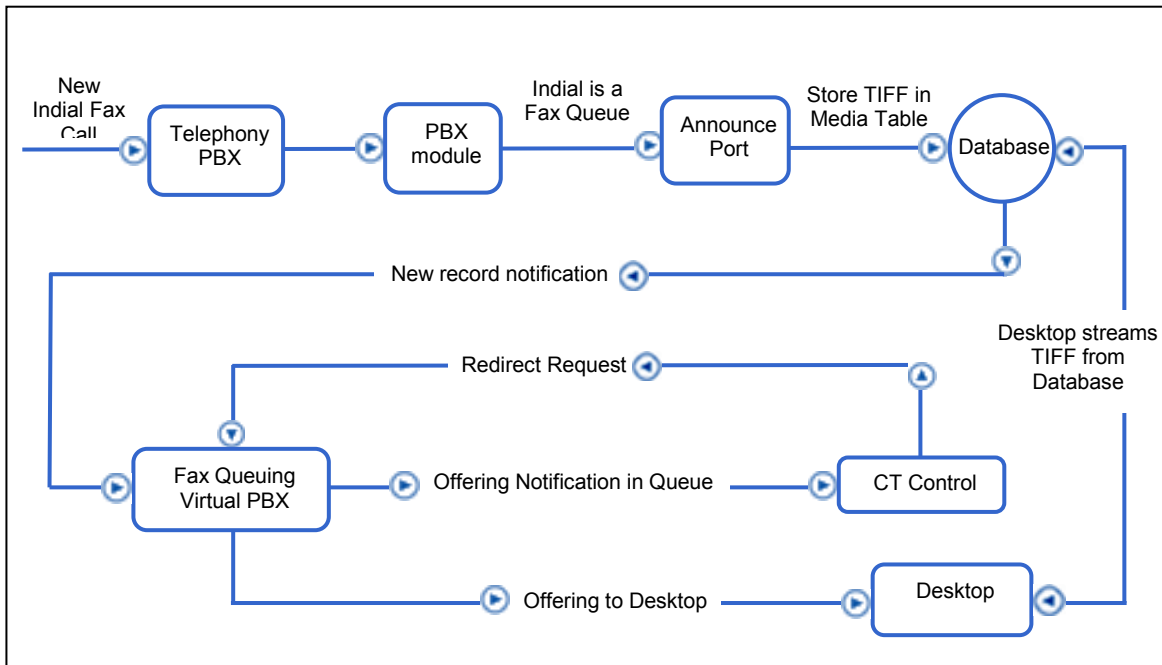

³ Note that the Cisco Unified Communications Manager, which uses the Router for inbound Fax, does not use Announce/voice ports.

Notifying Agents of Incoming Faxes

Features

As a fax arrives at the contact center, it is queued, waiting for delivery to the next available agent.

- Agents can be configured to handle just faxes, or to take a blend of multimedia and phone calls.
- Agents and managers can view waiting faxes via the Agent Desktop queues view screen (see example below).

Benefits

Viewing faxes in this manner has several benefits:

- By visually representing all faxes waiting in the queue, Fax Queuing makes it easy for managers to see the volume of faxes, and which agents are available to handle them.
- Faxes from recognized contacts can be selected for immediate delivery by the appropriate agent.

Example

The screen below shows the queues view as it would appear to an agent on their Agent Desktop. The waiting fax is presented to an agent in much the same way as a phone call, making fax an easily integrated addition to the contact center.

Figure 1. Desktop Queues

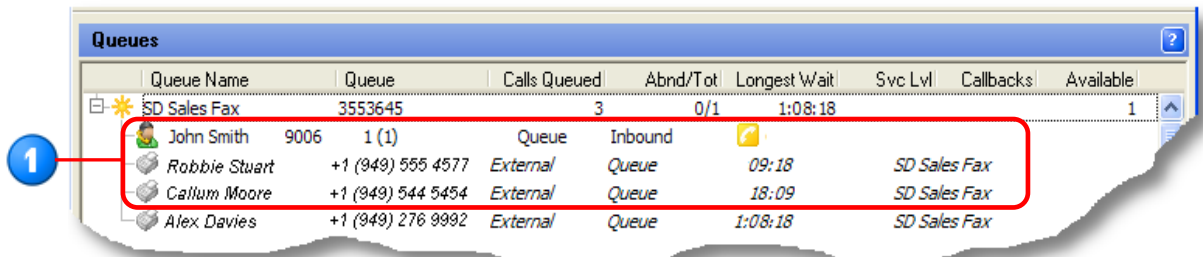

- 1 A waiting fax is presented to an agent in much the same way as a phone call, making fax an easily integrated addition to the contact center.

Fax Delivery to Agent

Features

When the fax is delivered to an agent:

- Agent Desktop can be popped to the front of any open applications.
- Agent Desktop will display the details of the fax, such as the sender's name and how long this person has been waiting.

Contact center managers can view fax activity, see how it is affecting the load on the contact center and make immediate decisions regarding the handling of these communications.

Benefits

The benefits of delivering faxes in this way are:

- Automatic delivery of faxes, and the use of screen pops save the agent time.
- Faxes are shared amongst available agents, distributing workload equally and efficiently.

Example

The fax is offered to the agent. The agent clicks: **Answer** to accept the fax.

- 1 The fax is offered to the agent.
- 2 The agent clicks **Answer** to accept the fax.

Figure 2. New Fax in Desktop

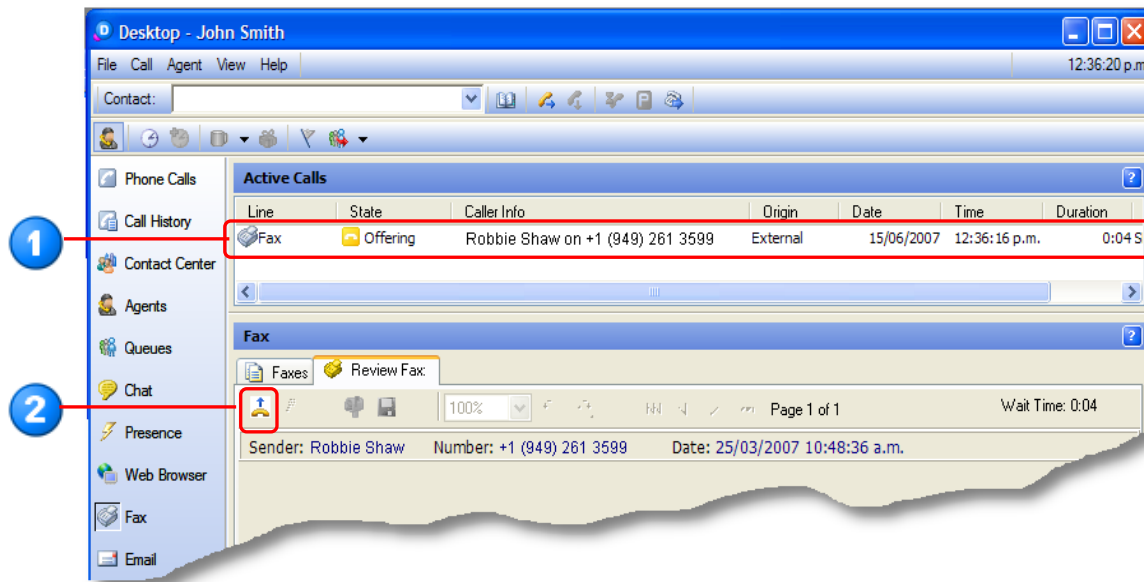

- 1 The inbound fax tab shows the connected fax with associated details.
- 2 The toolbar enables the user to manage the fax in view.
- 3 Duration shows how long the fax call has been open.
- 4 The body of the current fax is shown in the main pane of the tab.

Figure 3. Inbound Fax

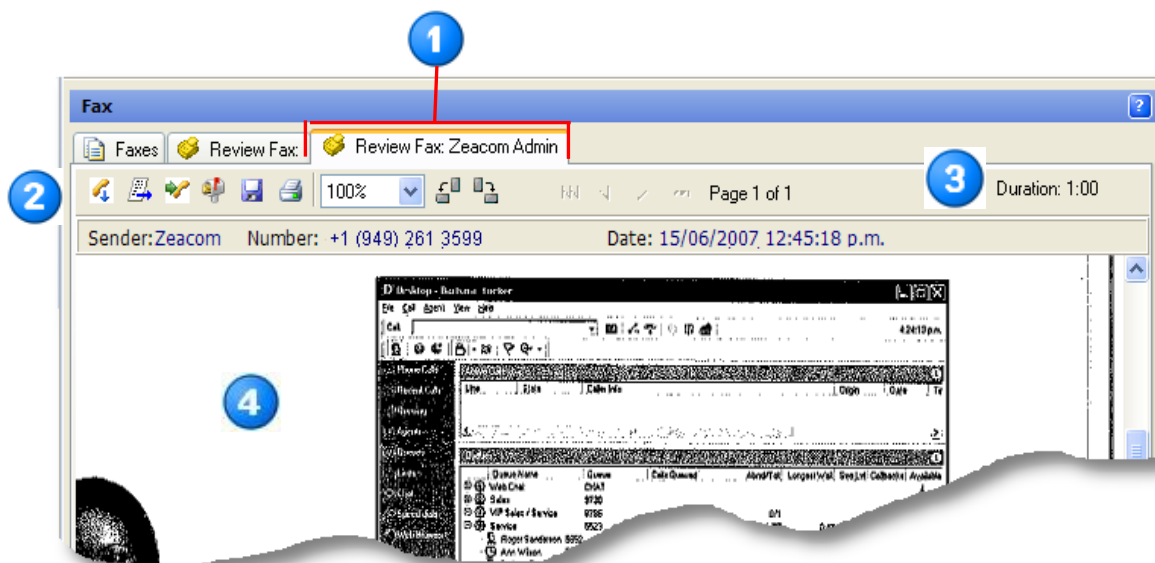

Additional Fax Queuing Functions

Features

The following additional features and functions are available when using Fax Queuing:

- A fax can be transferred to another agent by clicking the Transfer button which produces a list of the available agents to transfer to. The transferring agent can also cancel the transfer if they choose to.
- The Transfer button also displays a list of fax queues, so a fax can be transferred directly into another fax queue.
- The agent can click on the Hang up button to indicate (for Reporting purposes) that the Fax handling time is over. The agent can then click the X button to close the fax.
- Agents can save a copy of the fax either to their mailbox⁴ or to file for future reference.

⁴ Fax Messaging integration is required

- After the agent has completed the inbound queued fax, i.e., they have transferred or hung up on the fax, they can still view the 'Processed' fax in the main Faxes tab.
- Fax Queuing is administered from within the UCB solution. Because Fax Queuing is an integrated module, it shares most of the same call delivery and agent setup parameters used in the rest of the system.

Benefits

Fax Queuing provides agents with the flexibility to handle each fax in the manner appropriate to each individual communication.

- The transfer feature allows agents to use other expertise in the contact center to successfully resolve the call, while ensuring the ultimate destination is reported. If the second agent chooses to reply to the fax, each detail is still reported as part of the original call.
- Thanks to the "Answer" and "Hang up" buttons, reports accurately represent the amount of time spent handling the fax.
- Faxes do not need to be printed or paper filed, in order to be retained on record.
- Immediate, simple administration allows managers to provide a consistent level of service across media types.

Fax Queuing Reply

Features

Desktop agents can immediately reply to faxes received in the fax queue.

- Desktop agents can respond to queued faxes through customized fax response templates.
- The Fax Reply Template Editor allows administrators to create Fax Reply templates that agents can use when replying to queued faxes. Agents can choose the Templates from a drop down selection in the Desktop Fax plug-in view.
- Administrators can construct Fax reply templates using the following template tools: Label; Edit Box; Radio Button; Panel; Properties Field; Image Panel; Date Picker;

Time Picker; Group Box; Multi Line Editor; Combo Box and Check Box.

- Online Help is available for the Template Editor utility.
- Ease of use provided by the Windows GUI allows for sophisticated functionality without requiring a technician to come to site.
- Fax Queuing Reply converts the fax template to a TIFF image and saves it into a database. The voice ports then send the TIFF image to the requested destination.
- Replies are sent using ports on the server, so no additional hardware is required on the client PC.
- When the reply fax is ready to send, Desktop pops a "Send Fax" dialog (see Figure 7 below) offering the same number as the original fax came from. The agent can click OK to send, or adjust the displayed number to send to a different fax number.
- Desktop provides the option to include pages from the original fax in the reply, as a confirmation (see Figure 7 below).
- Agents can view a list of Fax Replies that have been sent, including the date and time and the result (such as 'sent' successfully, 'pending retry', or 'failed' to send).
- Agents can review the content of a Fax Reply they have sent. Double-clicking a fax listed on the Faxes tab displays the body of the fax in the Fax Call tab.
- Reports can be run on all queued inbound and outbound faxes.

Benefits

The ability to reply to faxes provides greater efficiency for the contact center which inevitably results in a higher service level to customers.

- The agent's ability to view fax traffic from within Desktop will improve the response time for fax calls, and raise customer satisfaction levels.
- Lost fax communications and slow response times are common customer frustrations when fax is the communication method. Your agents can now respond immediately to an inbound fax, without ever leaving their desk.

- Custom-designed fax templates ensure that customers receive a reply consistent with your contact center standards.
- Fax templates can be queue specific, prompting the agent to enter all the details required and ensuring that there is no room for confusion or customer uncertainty.
- Even in a “paperless” environment, agents can keep track on their own correspondence, printing and paper filing only as required.

Administrators and supervisors can evaluate and compare fax communications within the contact center against all other media using the same measurements, e.g., answer time, call handling time etc.

1

A new tab page is automatically generated for each fax that is opened or created.

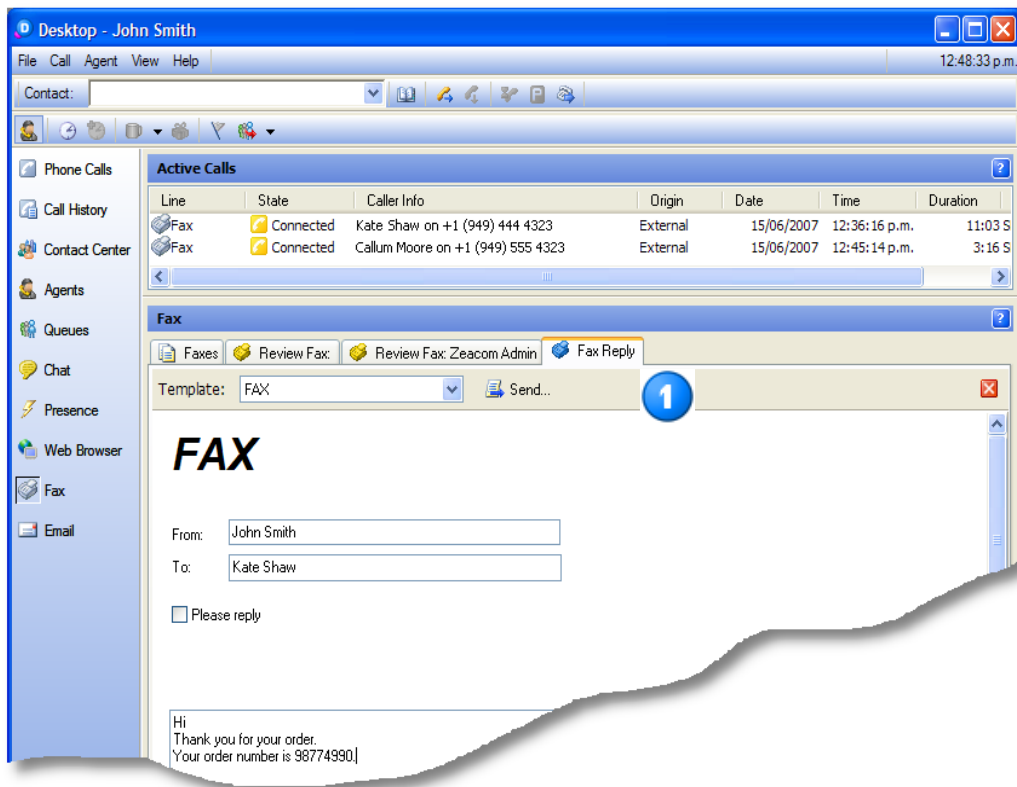

Figure 4. Fax Reply from Desktop

Figure 5. Include pages from original fax

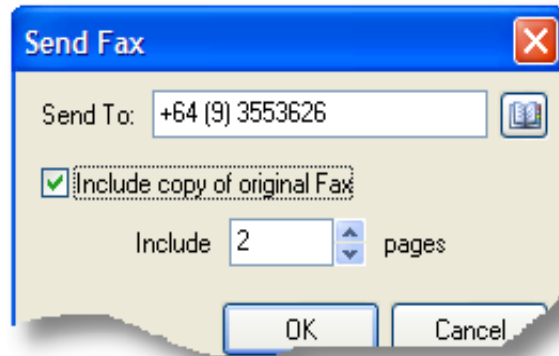
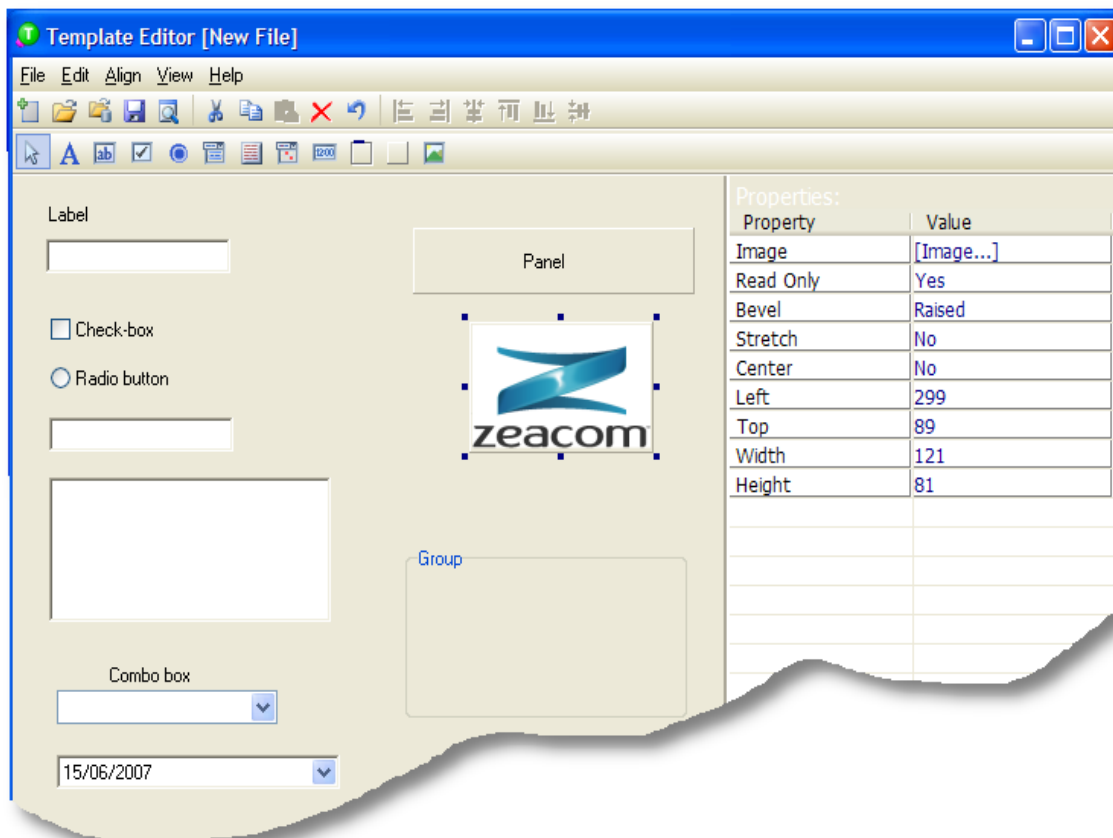

Figure 6. The Fax Reply Template Editor allows administrators to create Fax Reply templates that agents can use when replying to queued faxes.



- 1 Fax transmission information such as the date, the time and the number the fax was sent to.
- 2 Status of fax transmission such as 'Sent', 'Failed', 'Transmitting' or 'Pending: Retry #'. Fax messaging makes four attempts to send the fax; the transmission shows 'Failed' only after the fourth failed attempt.

From/To	Number	Date/Time	Status	Resent
Kate Shaw	+1 (949) 555 4323	19/03/2007 6:02:42 p.m.	Processed	
Robbie Davies	+1 (949) 444 5656	23/03/2007 12:09:50 a.m.	Processed	
Katie Smythe	+1 (949) 446 9700	15/06/2007 1:06:25 p.m.	Sent	
Barbara Smith	+1 (949) 276 9922	15/06/2007 1:11:04 p.m.	Failed	
Callum Moore	+1 (949) 478 7800	15/06/2007 1:11:48 p.m.	Cancelled	
Alex Browne	+1 (949) 476 5600	15/06/2007 1:19:47 p.m.	Failed	
Gabrielle Davis	+1 (949) 522 5707	15/06/2007 2:49:05 p.m.	Transmitting: Page 1	
Anna Stuart	+1 (949) 623 5606	15/06/2007 2:49:19 p.m.	Pending: 5 attempts left	

Figure 7. Sent Faxes list

Reports

Features

Reports for Fax Queuing traffic are accessed from the UCB standard Reports package.

The following standard reports are available for use with Fax Queuing:

- Queue Performance
- Queue Traffic Analysis
- Queue Traffic Comparison
- Queue Service Level
- Agent Performance
- Agent Activity
- Agent Availability
- Agent Summary
- Agent Multi-media
- X Seconds
- Call Type Analysis
- Wrapup Code
- Agent Wrapup Code
- Queue Wrapup Code
- Queue Historical
- Queue Historical Average
- Agent Historical
- Agent Historical Average
- Agent Setup
- Queue Setup

Specific Fax reports used for Fax Queuing are...

- Inbound Queue Fax Report
- Outbound Queue Fax Report
- Fax Destination Report

The Inbound Fax Queuing report provides statistics on call volume and sender/CLI details.

The Outbound Fax Queuing report provides information on faxes sent as replies from queue faxes with the following data:

- Did the agent respond?
- When did they respond?
- Number of faxes and pages sent
- Sent to (Fax number, Contact name, Company)
- Failed attempts: date, time, etc.
- Was the fax successfully sent / deleted / cancelled?

The Fax Destination report provides information on faxes that were sent or received:

- How many faxes were received from a particular customer/s or fax number over a specified period?
- How many faxes were sent to a particular customer/fax number, and when?

Benefits

The Reports application provides contact center managers with the flexibility to report on faxes side by side with other media, enabling them to identify agent activity and performance, or they can report on faxes specifically

- This provides more accurate reporting as service levels will vary according to media type; for example, fax wait times may be longer than phone wait times.
- Reporting provides valuable statistics to assist in the planning of schedules and delivery patterns. Supervisors and managers can apply standard contact center analysis to this media type.

- 1 Name of the queue that received the fax
- 2 CLI details of the contact sending the fax (if available)
- 3 Name of the contact (if CLI matches a Phonebook entry)
- 4 Company name of the contact (if CLI matches a Phonebook entry)

Figure 8. Example: Inbound Fax Report

Inbound Queue Fax Report						
For Queue(s) 'SUPPORT FAX Q (3557211)'						
For the period (1/05/2007 - 31/05/2007), (0:00:00-23:59:59), Detail 'All Details'						
Date	Time	Pages	CLI	Caller	Company	
SUPPORT FAX Q						
1/05/2007	12:06:42	1	+1 (949) 555 5600	Joe Davies	Zeacom USA	
2/05/2007	7:59:37	1	+1 (949) 276 9920	Martha Shaw	Mentor Co	
6/05/2007	14:30:42	1	+1 (949) 277 5606	Joseph Smythe	ABC Company	
6/05/2007	16:43:48	1	+1 (949) 486 5600	Mary Stuart		
7/05/2007	10:11:24	1	+1 (949) 477 2000	Barbara Davis	Fax Mailer Co	
14/05/2007	15:05:59	1	+1 (949) 356 3626	Paula Moore		
17/05/2007	15:05:35	1	+1 (949) 822 2660	Michael Smith	Zeacom USA	
18/05/2007	10:49:03	1	+61 (2) 7220 7222	Joe Moor	Zeacom Sydney	
18/05/2007	22:57:47	1	+1 (949) 277 5606	Joseph Smythe	ABC Company	

Media Viewer

Features

The Media Viewer allows supervisors to view details in and about previously handled multimedia contacts as well as the content. Launched from the main Tools menu, this application provides the ability to review details of chat, email, and fax conversations.

- Media Viewer allows you to go back and review the “conversations” that occur for specific call media.
- In the case of Fax, both the initial fax image as well as any fax reply images are captured and presented as the “conversation” for the call.

The Media Viewer is divided into two areas, the Calls window and the Preview window.

- The Media Viewer Calls window lists the calls (based on search criteria), providing an overview of the call details: the agent who received the call, caller ID if received and queue name/number that the call was delivered from.

- The Media Viewer Preview window allows you to review a specific call and its associated details e.g., a copy of the delivered fax.

Benefits

Media Viewer is both the “safety net” and “filing system” for a paperless office.

- Supervisors can attend to customer complaints relating to 'missing' faxes easily by utilizing the central media viewer tool.
- Fax traffic becomes yet another medium that can be reported on for contact center performance analysis.

Example

- 1 List the faxes received in the target period
- 2 Select the required fax
- 3 Display the fax

Figure 9. Media Viewer

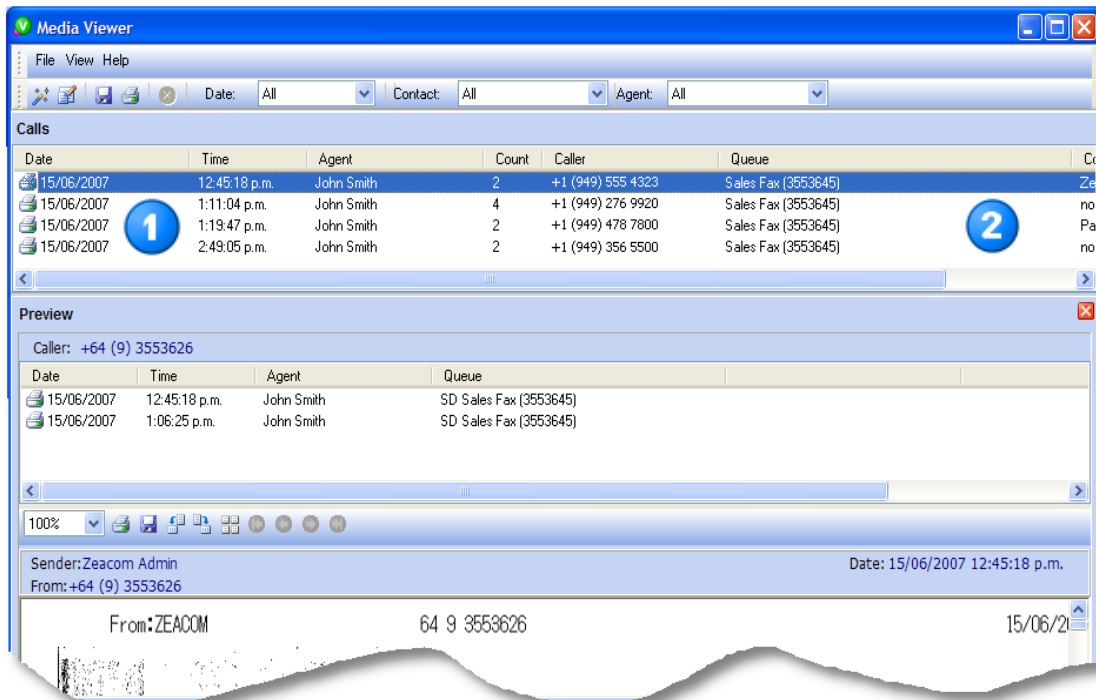

© 2009 NEC Corporation. All rights reserved. NEC, NEC logo, and UNIVERGE are trademarks or registered trademarks of NEC Corporation that may be registered in Japan and other jurisdictions. All trademarks identified with ® or ™ are registered trademarks or trademarks respectively. Please refer to your local NEC representatives for further details.